

April 2016

Type 6365 and 6358 Series Pilots

Introduction

Scope of the Manual

This Instruction Manual includes installation, maintenance and parts ordering information for the Type 6365 and 6358 Series relief pilots. For installation and operation of a complete relief valve assembly, refer to separate manuals (such as the Type EZR, 399A, 63EG, 289P, 1805P or 1808 relief valve).

Pilot Descriptions

Type 6365—Set pressure range from 14 in. w.c. to 2 psig / 35 mbar to 0.14 bar. This pilot has a high gain restriction standard.

Type 6358—Set pressure range from 3 to 125 psig / 0.21 to 8.62 bar. This pilot has a restriction plug.

Type 6358B—Set pressure range from 2 to 125 psig / 0.14 to 8.62 bar. This pilot is available with a high, medium or low gain restriction.

Type 6358EB—Set pressure range of 75 to 350 psig / 5.17 to 24.1 bar. This pilot is available with a high or low gain restriction.

Type 6358EBH—Set pressure range of 250 to 600 psig / 17.2 to 41.4 bar. This pilot is available with a high or low gain restriction.

Relief Valve

The pilot bleeds constantly while the relief valve is in operation. The pilot does not bleed when inlet pressure is below set pressure. The pilot exhaust can be connected directly to the main valve exhaust pipe if the pilot connection and the exhaust pipe are designed to prevent significant backpressure buildup during full-flow conditions.

The pilot restriction codes for Types 6365, 6358B, 6358EB and 6358EBH are indicated by a letter stamped on the bottom of the pilot body: an H for the yellow, high gain restriction (standard); S for the red, medium gain restriction; and L for the blue, low gain restriction. The high gain restriction has the lowest buildups and fastest speed of response.

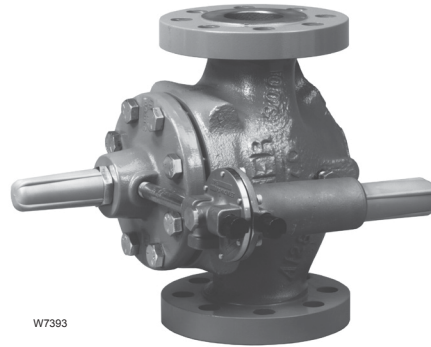

W7393

TYPE 6358EB MOUNTED
ON TYPE EZR

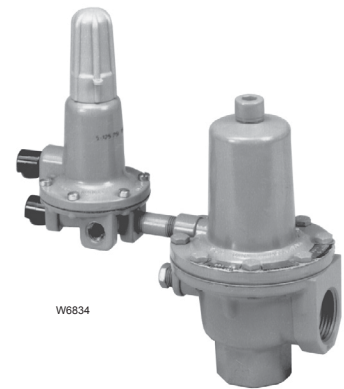

W6834

TYPE 6358B MOUNTED
ON TYPE 289P



W6913

TYPE 6358B MOUNTED
ON TYPE 1805P

Figure 1. Type 6358B Relief Pilot Mounted on Main Valves

Type 6365 and 6358 Series

Specifications

Specifications for various Type 6365 and 6358 Series pilot constructions are given on page 2. For each pilot (except the Type 6358 pilot, which has a plugged restriction), the restriction diameter is indicated by a letter stamped on the bottom of the pilot body next to the tapped side outlet. The pilot spring range appears on the pilot spring case.

<p>Maximum Relief (Inlet) Pressure (Including Buildup)⁽¹⁾</p> <p>Depends upon maximum inlet pressure for complete relief valve as specified in appropriate main valve bulletin</p> <p>Pilot Set Pressure Ranges⁽²⁾</p> <p>See Table 1</p>	<p>Temperature Capabilities⁽¹⁾</p> <p>-20 to 150°F / -29 to 66°C</p> <p>Pressure Connection</p> <p>1/4 in. NPT (internal)</p> <p>Approximate Weight</p> <p>2 lbs / 0.91 kg</p>
---	--

1. The pressure/temperature limits in this Instruction Manual and any applicable standard or code limitations must not be exceeded.
 2. Set pressure is defined as the pressure at which the pilot starts to discharge.

Table 1. Pilot Set Pressure Ranges and Control Spring Information

PILOT TYPE	SPRING RANGE ⁽¹⁾		PART NUMBER	SPRING COLOR	WIRE DIAMETER		FREE LENGTH	
	psig	bar			in.	mm	in.	mm
6365	14 in. w.c. to 2	35 mbar to 0.14	14A9672X012	Yellow	0.070	1.78	2.13	54.1
6358	3 to 18	0.21 to 1.24	1B986027212	Green	0.120	3.05	2.25	57.2
	10 to 40	0.7 to 2.76	1E392527022	Yellow	0.148	3.76	2.00	50.8
	20 to 125	1.4 to 8.62	1K748527202	Red	0.187	4.75	2.19	55.6
6358B	2 to 10	0.14 to 0.69	14A9673X012	Black	0.102	2.59	2.12	53.8
	3 to 18	0.21 to 1.24	1B986027212	Green	0.120	3.05	2.13	54.1
	10 to 30	0.69 to 2.07	1B788327022	Silver	0.142	3.61	2.13	54.1
	15 to 40	1.03 to 2.76	1E392527022	Yellow	0.148	3.76	2.00	50.8
	30 to 60	2.07 to 4.14	1B788427022	Blue	0.182	4.62	1.94	49.3
	10 to 125	0.7 to 8.62	1K748527202	Red	0.187	4.75	2.19	55.6
6358EB	75 to 140	5.17 to 9.65	17B1261X012	Green	0.225	5.72	3.70	94.0
	130 to 200	8.96 to 13.8	17B1263X012	Blue	0.262	6.66	3.85	97.8
	180 to 350	12.4 to 24.1	17B1264X012	Red	0.294	7.47	4.22	107
6358EBH	250 to 450	17.2 to 31.0	17B1263X012	Blue	0.262	6.66	3.85	97.8
	400 to 600	27.6 to 41.4	17B1264X012	Red	0.294	7.47	4.22	107

1. Main valve may limit advertised spring range. See individual main valve bulletin for additional information.

Backpressure Regulator

The Type 6358 is a low bleed pilot, so it only exhausts while it is repositioning the main valve which is useful for backpressure applications requiring zero bleed where the pilot exhaust can not be piped to the downstream piping. There is no constant bleed with this construction. This also minimizes dirt buildup in the pilot.

The Types 6365, 6358B, 6358EB and 6358EBH pilots can also be used in backpressure applications but they will bleed constantly while inlet pressure is above setpoint. Pilot exhaust can be piped into the downstream system on applications requiring no bleed.

Type 6365 and 6358 Series

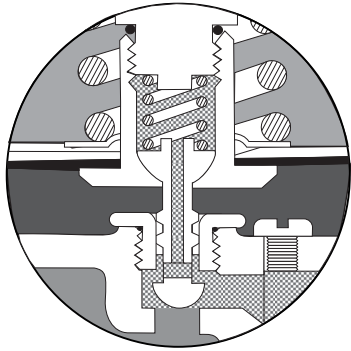

RESTRICTOR IN CLOSED POSITION

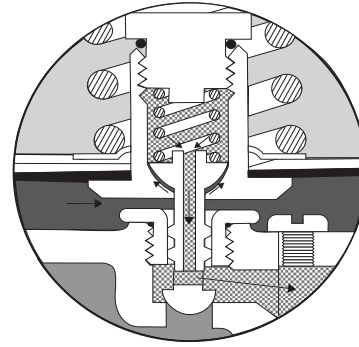

RESTRICTOR IN OPEN POSITION

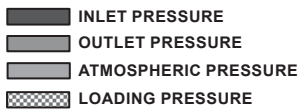

Figure 2. Type 6358 Restrictor Operational Schematic

Installation

WARNING

Installing a pilot where its capabilities, or those of any downstream equipment, can be exceeded may cause personal injury, property damage or leaking due to bursting of pressure-containing parts or explosion of accumulated gas or liquid. To avoid this, install these pilots where:

- Service conditions are within pilot capabilities (including those in specifications).
 - Installations comply with appropriate codes and regulations.
 - The unit is protected from physical damage and corrosive substances.
1. Only personnel qualified through training and experience should install, operate and maintain a pilot. Before installing, inspect the pilot for any damage and foreign material that may have collected in the body.
- Note**
- If the pilot is shipped mounted on a main valve, install the main valve according to the appropriate Instruction Manual.**
2. For a pilot that is shipped separately, make sure that there is no damage to, or foreign material in, the filter and that all tubing and piping have been cleaned. Install the pilot so that flow is from the IN to the OUT connection as marked on the pilot body.

WARNING

These pilots vent gas or liquids from their exhausts. In hazardous or flammable service, personal injury or property damage may occur due to fire or explosion of vented gas or liquid that has accumulated. To prevent such injury and damage, provide piping or tubing to vent the gas or liquid to a safe location. Protect the vent opening against anything that could block it.

3. A relief pilot must always be installed so that it exhausts properly and in a safe place. When the pilot is shipped mounted on a main valve, a vent is installed in the 1/4 in. NPT pilot exhaust connection. Unless it is an umbrella vent with its own built-in protection, this vent must be pointed down or otherwise protected.
4. The pilot exhaust may be piped directly into the main valve outlet (main valve stack with relief service) or piped into a separate low-pressure line. In either case, the diameter of the exhaust line or stack should be as large as practical with a minimum number of bends or other restrictions.
5. The standard pilot spring case has a gasketed closing cap and a pressed-in vent (key 16) installed in the 1/4 in. NPT spring case tapping. The vent may be removed and obstruction-free piping or tubing installed for remote piping or pressure loading of the spring case. If kept in the spring case, the vent must be pointed down or otherwise protected.
6. If using pipe, apply a good grade of pipe compound to the male pipe threads before making the connection. Install tubing or piping into the appropriate pilot connection.

Type 6365 and 6358 Series

7. Set pressure is defined as the pressure at which the pilot starts to discharge. The set pressure of a unit is adjusted by changing the control spring compression.
8. Each pilot is factory-set for the set pressure specified on the order. If no setting is specified, set pressure is factory-set at the midrange of the pilot control spring.

Maintenance



WARNING

Pilot parts are subject to normal wear and must be inspected and replaced as necessary. The frequency of inspection and replacement depends on the severity of service conditions and the requirements of local, state and federal rules and regulations.

Key numbers are referenced in Figures 4, 5 and 6 unless otherwise noted.



WARNING

Avoid personal injury or damage to property from sudden release of pressure or uncontrolled gas or other process fluid. Before starting to disassemble, carefully release all pressures according to the shutdown procedure. Use gauges to monitor inlet, loading and outlet pressures while releasing these pressures.

Disassembly

1. If necessary to check the outlet end of the body cavity and the seating surfaces for moisture or debris, remove the body plug (key 3) and body plug O-ring (key 13) from the body (key 1).
2. Remove the closing cap (key 12), loosen the locknut (key 11) and back out the adjusting screw (key 10) until compression is removed from the control spring (key 7).
3. Remove the machine screws (key 17) and separate the spring case (key 2) from the body assembly. Remove the control spring seat (key 8), the control spring (key 7) and if used, the diaphragm limiter (key 40).
4. Lift out the diaphragm assembly (key 5) and valve plug (key 4). Check the stem guide (key 9) and restriction (key 20) for damage or plugging. The Type 6358 has a restriction plug, not a restriction.

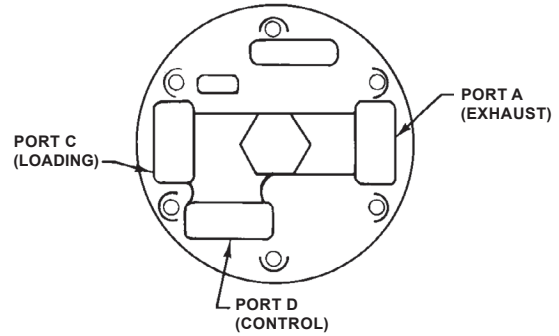

A3790

PORT A (EXHAUST)—THE MAIN VALVE LOADING PRESSURE IS DISCHARGED TO THE MAIN VALVE OUTLET OR TO ATMOSPHERE PRESSURE.

PORT C (LOADING)—A LOADING PRESSURE SIGNAL IS SENT FROM THIS PORT TO THE MAIN VALVE DIAPHRAGM CASING.

PORT D (CONTROL)—THE MAIN VALVE INLET PRESSURE IS SENSED AT THIS PORT.

Figure 3. Pilot Port Functions

5. If necessary to replace the diaphragm assembly, the valve plug (key 4), the valve spring (key 14) or the stem O-ring (key 37), remove the connector cap (key 6) and connector cap O-ring or gasket (key 36) from the top of the diaphragm assembly.

Assembly

1. If removed, install the body plug O-ring (key 13) over the body plug (key 3), and install the body plug into the body (key 1).
2. Install the stem guide (key 9), if removed, and make sure to install the connector cap O-ring or gasket (key 36) between the body (key 1) and the stem guide.

Note

In step 3, if installing a different size restriction, be sure to remove the code letter on the bottom of the pilot and indicate the new letter.

3. If the restriction or restriction plug (key 20) was removed, coat the threads with lubricant and install it.
4. If replacing the stem O-ring (key 37), sparingly apply lubricant and install the O-ring over the valve plug (key 4).
5. If removed, install the valve plug (key 4) and valve spring (key 14) into the diaphragm assembly (key 5). Install a replacement connector cap O-ring or gasket (key 36) on the diaphragm assembly, and secure with the connector cap (key 6).
6. Install the diaphragm assembly (key 5) and push down on it to see if the valve plug (key 4) moves smoothly. The diaphragm assembly should stroke approximately 1/16 in. / 1.60 mm after the valve plug contacts the port.

Type 6365 and 6358 Series

Note

In step 7, if installing a control spring of a different set pressure range, be sure to remove the set pressure range on the spring case and indicate the new range.

7. Stack the control spring (key 7), the control spring seat (key 8), and, if used, the diaphragm limiter (key 40) onto the diaphragm assembly (key 5). Make sure to install the diaphragm limiter beveled side up.
8. Install the spring case (key 2) on the body (key 1) with the vent assembly (key 16) oriented to prevent clogging or entrance of moisture. Install the machine screws (key 17) and tighten in a crisscross pattern, using 5 to 7 ft-lbs / 7 to 9 N•m of torque.
9. Replace the closing cap gasket (key 19) if necessary, and install the closing cap (key 12). When all maintenance is complete, refer to the Startup and Adjustment section to put the relief valve or backpressure regulator into operation and adjust the pressure setting.

Parts Ordering

When corresponding with your local Sales Office about this pilot, include the type number and all other pertinent information stamped on the bottom of the body and on the spring case. Also include the main valve serial number. Specify the eleven-character part number when ordering new parts from the following parts list.

Parts List

6358 Series Pilots

Key	Description	Part Number
	Parts Kit (included are keys 4, 5, 13, 14, 19, 36, 37 and P590 Series Filter keys 2 and 7).	
	Type 6358 parts kit	R6358X00072
	Type 6358B	R6358X00032
	Type 6358EB (75 to 200 psig / 5.17 to 13.8 bar)	R6358X00052
	Type 6358EB (180 to 350 psig / 12.4 to 24.1 bar)	R6358X00062
	Type 6358EBH	R6358X00072
1	Body	
	Aluminum	39A0138X012
	Stainless steel (NACE)	39A5972X012
2	Spring Case	
	Types 6358 and 6358B	
	Aluminum	25A6220X012
	Stainless steel	28A9277X012
	Types 6358EB and 6358EBH	
	Stainless steel	27B9722X012
3	Body Plug	
	Aluminum	1B797509032
	Stainless steel	1B7975X0052
	Stainless steel (NACE)	1B797535072

Key	Description	Part Number
4	Valve Plug and Stem Assembly	
	Types 6358 and 6358B	
	Stainless steel/Nitrile (NBR)	14B6372X012
	Stainless steel/Plastic	16A2924X012
	Types 6358EB and 6358EBH	
	Stainless steel/Nitrile (NBR)	18B3427X012
	Stainless steel/Fluorocarbon (FKM)	18B3427X022
	Stainless steel/Plastic	16A2924X012
5*	Diaphragm Assembly	
	Types 6358 and 6358B	
	Nitrile (NBR)	15A6216X072
	Nitrile (NBR) (NACE)	15A6216X212
	Fluorocarbon (FKM)	15A6216X172
	Type 6358EB	
	Nitrile (NBR)	
	75 to 200 psig / 5.17 to 13.8 bar	18B3428X012
	75 to 200 psig / 5.17 to 13.8 bar (NACE)	18B3428X032
	180 to 350 psig / 12.4 to 24.1 bar	18B3428X022
	Fluorocarbon (FKM)	
	75 to 200 psig / 5.17 bar to 13.8 bar	18B3428X042
	180 to 350 psig / 12.4 to 24.1 bar	18B3428X052
	Type 6358EBH	
	Nitrile (NBR)	
	250 to 600 psig / 17.2 to 41.4 bar	18B3429X012
6	Connector Cap	
	Types 6358 and 6358B	
	Standard	16A2921X012
	NACE	16A2921X022
	Types 6358EB and 6358EBH	
	Standard	14B9813X012
	NACE	14B9813X022
7	Control Spring	See Table 1
8	Spring Seat, Zinc-plated steel	
	Types 6358 and 6358B	1B798525062
	Types 6358EB and 6358EBH	17B0515X012
9	Stem Guide	
	Standard	16A2923X012
	NACE	16A2923X022
10	Adjusting Screw	
	Types 6358 and 6358B	10B7192X012
	Type 6358EB (75 to 140 psig / 5.17 to 9.65 bar range spring)	17B1227X012
	Type 6358EB (130 to 200 psig / 9.0 to 13.8 bar range spring)	10B3081X012
	Type 6358EB (180 to 350 psig / 12.4 to 24.1 bar range spring)	10B3080X012
	Type 6358EBH	10B3080X012
11	Locknut, Plated steel	
	Types 6358 and 6358B	1A946324122
	Types 6358EB and 6358EBH	1D667728982
12	Closing Cap	
	Types 6358 and 6358B	
	Plastic	23B9152X012
	Stainless steel	1H2369X0032
	Aluminum (NACE)	1H2369X0012
	Types 6358EB and 6358EBH	24B1301X012
13*	Body Plug O-ring	
	Composition	1C495704022
	Nitrile (NBR)	1F113906992
	Fluorocarbon (FKM)	1N463906382
14	Valve Spring	
	Types 6358, 6358EB and 6358EBH	
	Stainless steel, standard	1E701337022
	Inconel®, NACE	19A8179X012
	Type 6358B	
	Stainless steel	1E701337022
	Inconel®, Standard	17A2328X012
	Inconel®, NACE	19A8179X012
15	O-ring, Type 6358EBH, Nitrile (NBR)	10A7777X012

* Recommended Spare Parts
Inconel® is a mark owned by Special Metals Corporation.

Type 6365 and 6358 Series

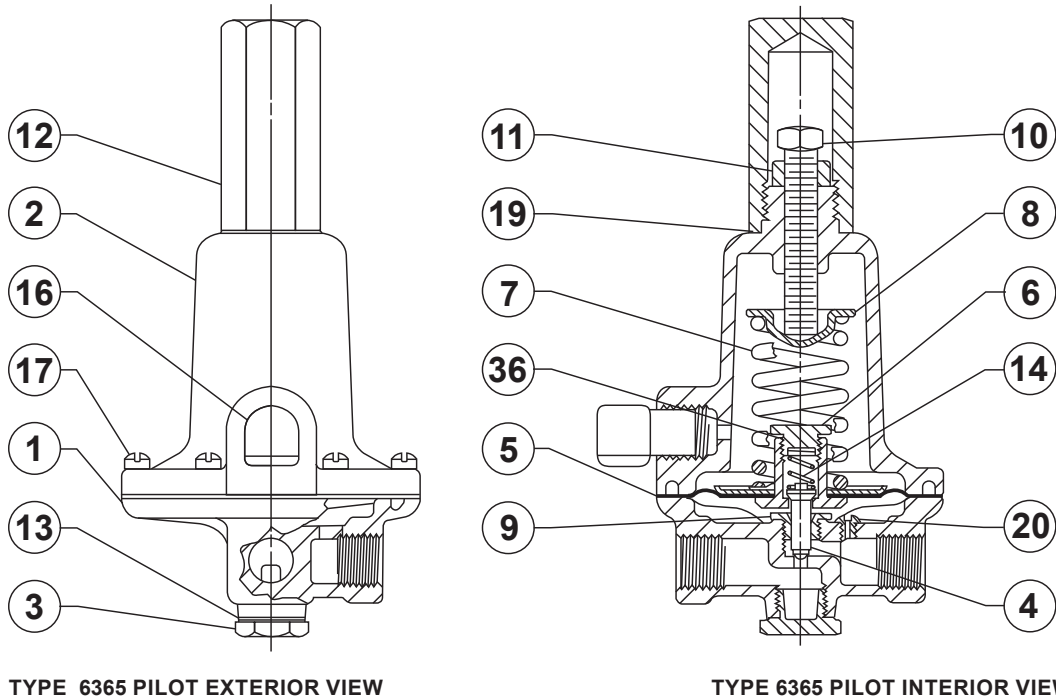
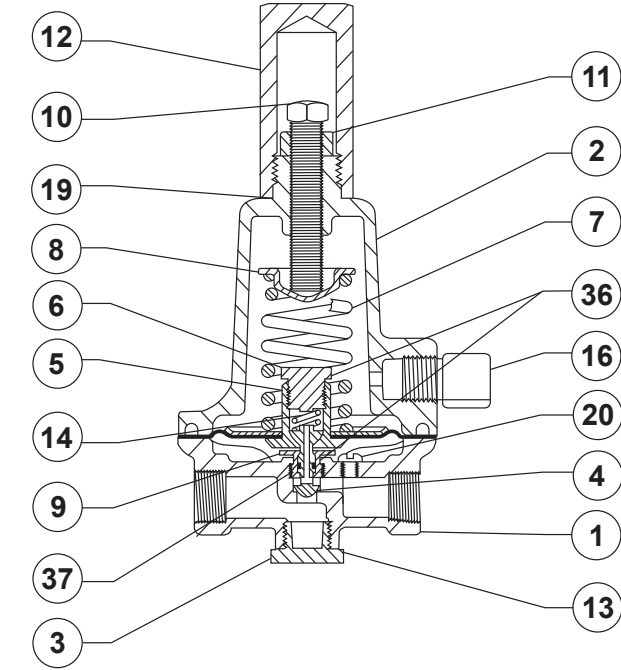

Figure 4. Type 6365 Pilot Assembly

Key	Description	Part Number	Key	Description	Part Number
16*	Vent Assembly, plastic Standard For mounting on Type 1808 (Without upstream registration)	Type Y602-12	29	Gauge Types 6358 and 6358B For Type 63EG 0 to 60 psig / 0 to 4.14 bar / 0 to 0.4 MPa	11B8582X022
17	Machine Screw (6 required) Type 6358 Aluminum body, Stainless steel	Type Y602-11		0 to 160 psig / 0 to 11.0 bar / 0 to 1.1 MPa	11B8582X032
	Stainless steel body, Steel	10B6189X022		For Type 1808 0 to 160 psig / 0 to 11.0 bar / 0 to 1.1 MPa	11B8579X042
	Type 6358B, Stainless steel	1V4360X0022		Types 6358EB and 6358EBH For Type 63EG	
	Type 6358EB, Steel	1V4360X0022		0 to 160 psig / 0 to 11.0 bar / 0 to 1.1 MPa	11B8580X032
	Type 6358EBH, Steel	T12980T0012		0 to 300 psig / 0 to 20.7 bar / 0 to 2 MPa	11B8580X042
18	O-ring, Type 6358EB Nitrile (NBR)	10A0904X012		0 to 400 psig / 0 to 27.6 bar / 0 to 2.8 MPa	11B8580X072
	Fluorocarbon (FKM)	10A0904X032		0 to 600 psig / 0 to 41.4 bar / 0 to 4.1 MPa	11B8580X082
19*	Closing Cap Gasket Types 6358 and 6358B, composition	15A6218X012	29	Pipe Plug Steel	1A767524662
20	Restriction Plug, Type 6358 Standard	1A346128982		Stainless steel	1A767535072
	NACE	1V7435X0012	34	Pipe Nipple Types 6358 and 6358B	
20	Restriction Type 6358B Standard and NACE			Standard, Zinc-plated	1C488226232
	High Gain	17A7279X012		NACE, Stainless steel	1C488238982
	Medium Gain	17A2029X012		Types 6358EB and 6358EBH NACE, Stainless steel	1C488238982
	Low Gain	17A7277X012	36*	Connector Cap Gasket Fluorocarbon (FKM) (2 required)	1U1716X0012
	Types 6358EB and 6359EBH Standard and NACE		37*	Stem O-ring Nitrile (NBR)	16A2920X012
	High Gain	17A7279X012		Fluorocarbon (FKM)	16A2920X022
	Low Gain	17A2030X012	38	Lower Spring Seat, Thermoplastic Types 6358EB and 6358EBH	18B1248X012
21	Filter Types 6358 and 6358B Standard	Type P594-1	40	Diaphragm Limiter Type 6358EB	10B4407X012
	Corrosive and NACE	Type P593-1	42	NACE Tag, Stainless steel	19A6034X012
	Types 6358EB and 6358EBH Standard and NACE	Type 252	43	Tag Wire, Stainless steel	1U7581X0022

* Recommended Spare Parts

Type 6365 and 6358 Series



A6920

TYPE 6358 PILOT INTERIOR VIEW

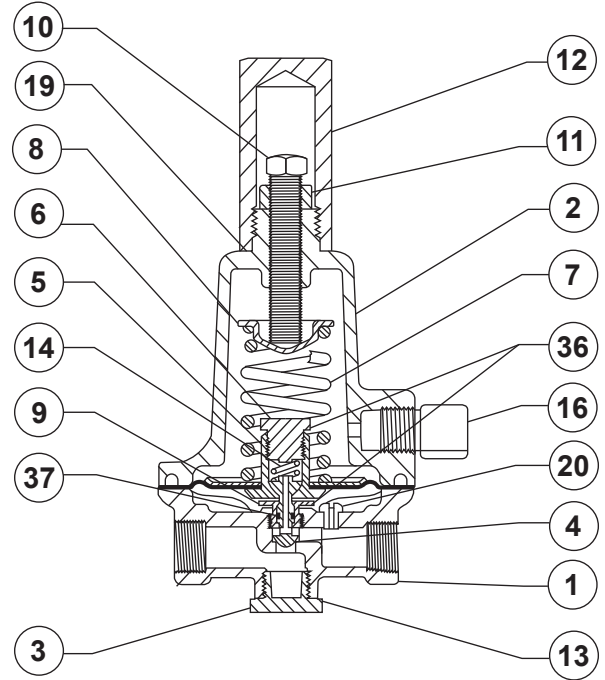

B2619-2

TYPE 6358B PILOT INTERIOR VIEW

Figure 5. Types 6358 and 6358B Pilots

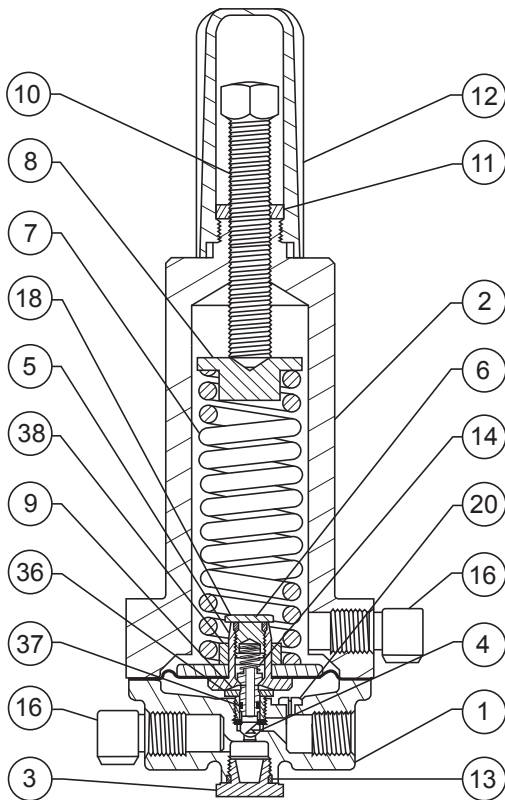

B2620-2

TYPE 6358EB PILOT INTERIOR VIEW

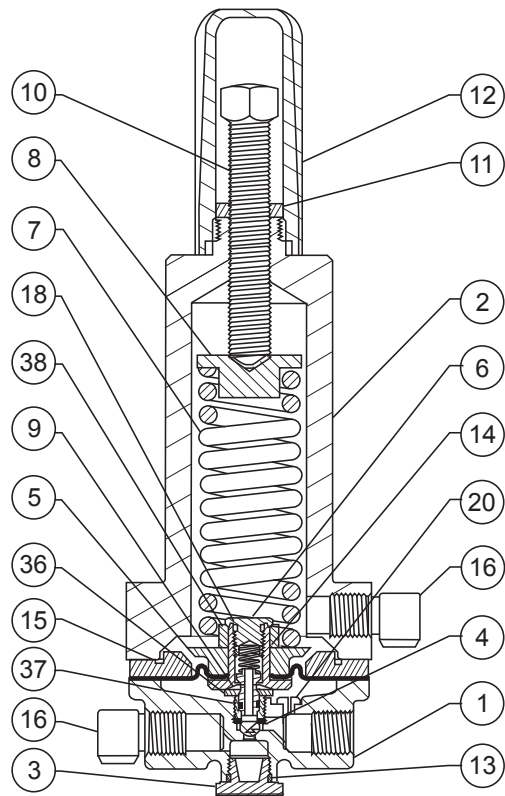

B2621-2

TYPE 6358EBH PILOT INTERIOR VIEW

Figure 6. Types 6358EB and 6358EBH Pilots

Type 6365 and 6358 Series

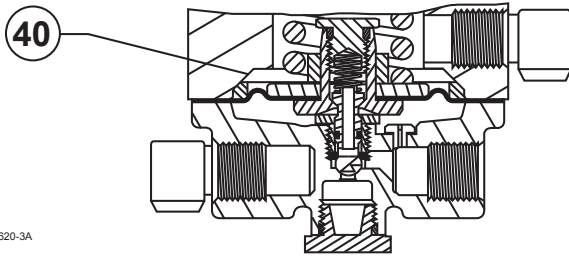

B2620-3A

**DETAIL OF TYPE 6358EB PILOT DIAPHRAGM LIMITER FOR
180 TO 350 psig / 12.4 TO 24.1 bar SET PRESSURE RANGE INTERIOR VIEW**

Figure 6. Types 6358EB and 6358EBH Pilots (continued)

Type 6365 Pilot

Key	Description	Part Number	Key	Description	Part Number
	Parts Kits (included are keys 4, 5, 13, 14, 19 and 36)	R6365X00012	9	Plug/Stem Guide, Stainless steel	16A2923X012
1	Body Assembly, Aluminum	39A0138X012	10	Adjusting Screw, Plated steel	10B3692X012
2	Spring Case, Aluminum	25A6220X012	11	Locknut, Zinc-plated steel	1A946324122
3	Body Plug, Aluminum	1B797509032	12	Closing Cap, Plastic	23B9152X012
4*	Plug/Stem Assembly		13*	Body Plug Gasket, Composition	1C495704022
	Nitrile (NBR) plug with stainless steel stem	19A0137X122	14*	Plug/Stem Spring, Inconel® X750	17A2328X012
5*	Diaphragm Assembly Steel and Nitrile (NBR)	15A6216X612	16	Vent Assembly, Plastic	Type Y602-12
6	Connector Cap, Stainless steel	16A2921X012	17	Machine Screw, Stainless steel (6 required)	10B6189X022
7	Control Spring, Zinc-plated steel		19*	Closing Cap Gasket, Composition	15A6218X012
	14 in. w.c. to 2 psig / 35 mbar to 0.14 bar	14A9672X012	20	Restriction, Plated carbon steel	
8	Spring Seat, Zinc-plated	1B798525062		Indicated by H for high gain stamped on pilot body and yellow color code	17A7279X012
			36*	Connector Cap Gasket, Fluorocarbon (FKM)	1U1716X0012

* Recommended Spare Parts
Inconel® is a mark owned by Special Metals Corporation.

Industrial Regulators

Emerson Process Management Regulator Technologies, Inc.

USA - Headquarters
McKinney, Texas 75070 USA
Tel: +1 800 558 5853
Outside U.S. +1 972 548 3574

Asia-Pacific
Shanghai 201206, China
Tel: +86 21 2892 9000

Europe
Bologna 40013, Italy
Tel: +39 051 419 0611

Middle East and Africa
Dubai, United Arab Emirates
Tel: +971 4811 8100

Natural Gas Technologies

Emerson Process Management Regulator Technologies, Inc.

USA - Headquarters
McKinney, Texas 75070 USA
Tel: +1 800 558 5853
Outside U.S. +1 972 548 3574

Asia-Pacific
Singapore 128461, Singapore
Tel: +65 6770 8337

Europe
Bologna 40013, Italy
Tel: +39 051 419 0611
Chartres 28008, France
Tel: +33 2 37 33 47 00

Middle East and Africa
Dubai, United Arab Emirates
Tel: +971 4811 8100

TESCOM

Emerson Process Management Tescom Corporation

USA - Headquarters
Elk River, Minnesota 55330-2445, USA
Tels: +1 763 241 3238
+1 800 447 1250

Europe
Selmsdorf 23923, Germany
Tel: +49 38823 31 287

Asia-Pacific
Shanghai 201206, China
Tel: +86 21 2892 9499

For further information visit www.fisherregulators.com

The Emerson logo is a trademark and service mark of Emerson Electric Co. All other marks are the property of their prospective owners. Fisher is a mark owned by Fisher Controls International LLC, a business of Emerson Process Management.

The contents of this publication are presented for informational purposes only, and while every effort has been made to ensure their accuracy, they are not to be construed as warranties or guarantees, express or implied, regarding the products or services described herein or their use or applicability. We reserve the right to modify or improve the designs or specifications of such products at any time without notice.

Emerson Process Management Regulator Technologies, Inc. does not assume responsibility for the selection, use or maintenance of any product. Responsibility for proper selection, use and maintenance of any Emerson Process Management Regulator Technologies, Inc. product remains solely with the purchaser.